

Proportional relief valves type **AGMZO-TERS, AERS**

two stage, with integral or remote pressure transducer, ISO 6264 size 10, 20 and 32

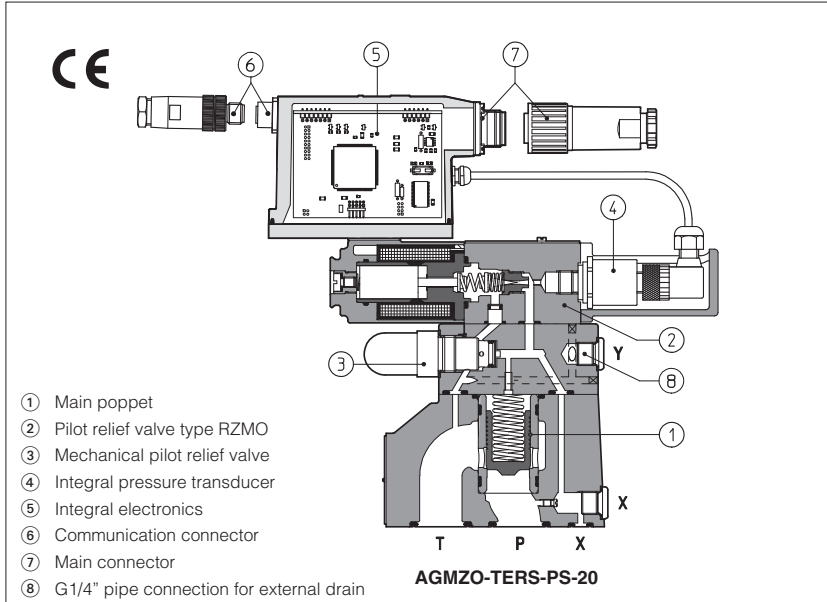

1 MODEL CODE

AGMZO	-	TERS	-	PS	-	10 / 315	/	*	/	**	/	*
<p>Proportional relief valve</p> <p>TERS = with integral digital electronics and pressure transducer AERS = as TERS but predisposed for connection of remote pressure transducer (to be ordered separately, see tab. G460)</p> <p>Communication interfaces: PS = Serial BC = CANopen BP = PROFIBUS-DP</p> <p>Size: 10, 20, 32</p> <p>Pressure range: 100 = 100 bar 210 = 210 bar 315 = 315 bar</p>												
<p>Synthetic fluids WG = water-glycol PE = phosphate ester</p> <p>Series number</p> <p>Hydraulic options, see section 6: E = external pilot Y = external drain (only pipe connection G1/4") (1)</p> <p>Electronics options, see section 6: I = current reference input and monitor (4 ÷ 20 mA) signals Z = double power supply, enable fault and monitor signals (12 pin connector) C = remote pressure transducer with current feedback 4÷20 mA (only for AERS executions)</p>												

(1) External drain (option Y) is advisable in case T line is pressurized

AGMZO are two stage poppet type proportional pressure relief valves, with integral or remote pressure transducer, which provide pressure regulation proportional to electronic reference signal.

They operate in association with electronic drivers, see table 2, which supply the proportional valve with proper current to align valve regulation to the reference signal supplied to the electronic driver.

They are available in different executions:

- -TERS with integral pressure transducer 4 plus digital electronics 5 preset in closed loop, featuring improved static and dynamic performances.
- -AERS as -TERS but without integral pressure transducer (predisposed for connection of remote pressure transducer).

The piloting pressure to the main poppet 1 is modulated by a proportional pilot relief valve type RZMO 2, see table F010.

The mechanical relief valve 3 with manual adjustment is installed to limit the max pressure value.

The integral electronics ensures factory presetting, fine functionality plus valve-to-valve interchangeability and simplified wiring and installation.

The electronic main connector 7 is fully interchangeable for -TERS and -AERS executions. Standard 7 pin connector is used for power supply, analog input reference and monitor signals. 12 pin connector is used for option /Z.

Following communication interfaces 6 are available:

- -PS, Serial communication interface for configuration, monitoring and firmware updating trough Atos PL software
- -BC, CANopen interface
- -BP, PROFIBUS DP interface

The valves with -BC and -BP interfaces can be integrated into a fieldbus communication network and thus digitally operated by the machine control unit.

The coils are fully plastic encapsulated (insulation class H), and the valves have antivibration, antishock and weather-proof features.

Surface mounting: ISO 6264 size 10, 20 and 32.

Max flow: 200, 400, 600 l/min
 Max pressure: 315 bar.

2 ELECTRONIC DRIVERS FOR AGMZO

Valve model	-TERS	-AERS
Drivers model	E-RI-TERS	E-RI-AERS
Data sheet	G205	

Note: for power supply and communication connector see section 11

3 HYDRAULIC CHARACTERISTICS (based on mineral oil ISO VG 46 at 50 °C)

Hydraulic symbols			
Valve model	AGMZO-TERS		AGMZO-AERS
Size	10	20	32
Max regulated pressure [bar]	100; 210; 315		
Min. regulated pressure (Q = 25 l/min) [bar]	7	6	5,5
Max pressure at port P [bar]	315		
Max pressure at port T [bar]	210		
Max flow [l/min]	200	400	600
Response time 0 - 100% step signal (depending on installation) - see section 9.4 [ms]	80	100	115
Hysteresis [% of the max pressure]	≤ 0,5		
Linearity [% of the max pressure]	≤ 1,0		
Repeatability [% of the max pressure]	≤ 0,2		
Thermal drift	zero point displacement < 1% at ΔT = 40°C		

4 MAIN CHARACTERISTICS OF PROPORTIONAL PRESSURE RELIEF VALVES TYPE AGMZO

Assembly position	Any position
Subplate surface finishing	Roughness index, \sqrt{Ra} flatness ratio 0,01/100 (ISO 1101)
Ambient temperature	-20°C ÷ +50°C for -TERS and -AERS
Fluid	Hydraulic oil as per DIN 51524 ... 535 for other fluids see section 11
Recommended viscosity	15 ÷ 100 mm ² /s at 40°C (ISO VG 15÷100)
Fluid contamination class	ISO 18/15 achieved with in line filters of 10 μm and β ₁₀ ≥ 75 (recommended)
Fluid temperature	-20°C +60°C (standard and /WG seals) -20°C +80°C (/PE seals)
Coil resistance R at 20°C	3 ÷ 3.3 Ω
Max solenoid current	2,6 A
Max power	40 Watt
Protection degree (CEI EN-60529)	IP67
Duty factor	Continuous rating (ED=100%)

5 GENERAL NOTES

AGMZO are poppet type proportional pressure relief valves CE marked according to the applicable Directives (e.g. Immunity/Emission EMC Directive and Low Voltage Directive).

Installation, wirings and start-up procedures must be performed according to the general prescriptions shown in table F003 and in the installation notes supplied with relevant components.

The electrical signals of the valve (e.g. monitor signals) must not be directly used to activate safety functions, like to switch-ON/OFF the machine's safety components, as prescribed by the European standards (Safety requirements of fluid technology systems and components-hydraulics, EN-982).

6 DIGITAL INTEGRAL DRIVERS -TERS and -AERS -OPTIONS

Standard driver execution provides on the 7 pin main connector:

Power supply - 24Vdc must be appropriately stabilized or rectified and filtered; a 2,5 A safety fuse is required in series to each driver power supply. Apply at least a 10000 μF/40 V capacitance to single phase rectifiers or a 4700 μF/40 V capacitance to three phase rectifiers

Reference input signal - analog differential input with 0÷+10 Vdc nominal range (pin D,E), proportional to desired valve pressure regulation

Monitor output signal - analog output signal proportional to the actual valve pressure regulation = 0÷+10 Vdc nominal range

Following options are available to adapt standard execution to special application requirements:

6.1 Option /I

It provides 4±20 mA current reference and monitor signals instead of the standard 0÷+10 Vdc.

It is normally used in case of long distance between the machine control unit and the valve or where the reference signal can be affected by electrical noise; the valve functioning is disabled in case of reference signal cable breakage.

6.2 Option /Z

It provides on 12 pin main connector the following additional features

Logic power supply

Separated power supply for the solenoid (pin 1, 2) and for the digital electronic circuits (pin 9, 10).

Cutting solenoid power supply allows to interrupt the valve functioning but keeping energized the digital electronics thus avoiding fault conditions of the machine fieldbus controller. This condition allows to realize safety systems in compliance with European Norms EN13849-1 (ex EN954-1).

Enable Input Signal

To enable the driver, supply 24Vdc on pin 3 referred to pin 2: when the Enable signal is set to zero the valve functioning is disabled (zero current to the solenoid) but the driver current output stage is still active.

Fault Output Signal

Fault output signal indicates fault conditions of the driver (solenoid short circuits/not connected, reference signal cable broken for 4±20mA input, etc.). Fault presence corresponds to 0 Vdc, normal working corresponds to 24Vdc (pin 11 referred to pin 2): Fault status is not affected by the Enable input signal

6.3 Option /C (only for -AERS version)

The valve electronics is set to receive the 4±20 mA feedback signal from the remote pressure transducer, instead of the standard 0÷10 V.

6.4 Possible combined options: /CI, /CIZ, /CZ (only for -AERS) and /IZ.

7 DIGITAL INTEGRAL DRIVERS -TERS and -AERS -main functions and electronic connectors

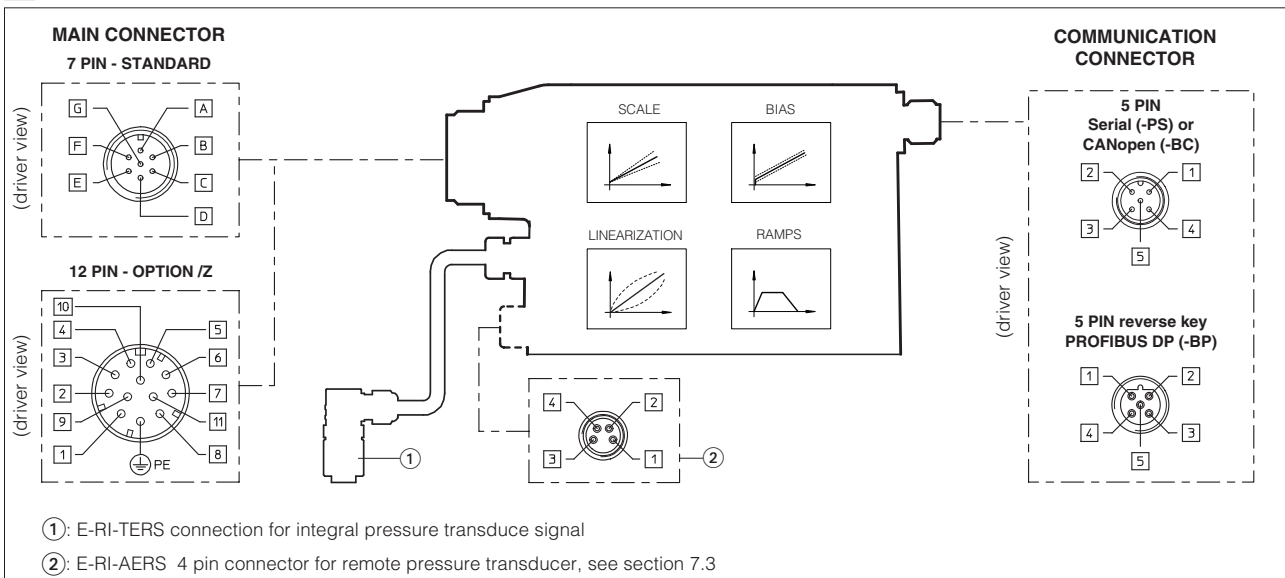

7.1 ELECTRONIC CONNECTIONS - 7 & 12 PIN MAIN CONNECTOR

Standard 7pin	/Z option 12pin	SIGNAL	TECHNICAL SPECIFICATIONS	NOTES
A	1	V+	Power supply 24 Vdc for solenoid power stage (and for driver logic on 7 pin connection)	Input - power supply
B	2	V0	Power supply 0 Vdc for solenoid power stage (and for driver logic on 7 pin connection)	Gnd - power supply
-	3	ENABLE	Enable (24 Vdc) or disable (0 Vdc) the driver	Input - on/off signal
D	4	INPUT+	Reference analog input: ± 10 Vdc maximum range (4 \div 20 mA for /I option) Normal working range 0 \div +10 Vdc (4 \div 20 mA for /I option)	Input - analog signal
E	-	INPUT-	differential INPUT+ and INPUT - (for 7 pin standard execution) common mode INPUT+ referred to AGND (only for /Z option)	
C	5	AGND	Ground : signal zero for MONITOR signal (pin F of 7 pin standard or pin 6 of /Z option) signal zero for INPUT+ signal (only for /Z option)	Gnd - analog signal
F	6	MONITOR	Monitor analog output: ± 10 Vdc maximum range (4 \div 20 mA for /I option)	Output - analog signal
-	7	NC	do not connect	
-	8	NC	do not connect	
-	9	VL+	Power supply 24 Vdc for driver's logic	Input - power supply
-	10	VL0	Power supply 0 Vdc for driver's logic	Gnd - power supply
-	11	FAULT	Driver status : Fault (0Vdc) or normal working (24 Vdc)	Output - on/off signal
G	PE	EARTH	Internally connected to driver housing	

Note: A minimum time of 270 to 590 ms have be considered between the driver energizing with the 24 Vdc power supply and when the valve is ready to operate. During this time the current to the valve coils is switched to zero

7.2 ELECTRONIC CONNECTIONS - 5 PIN COMMUNICATION CONNECTORS

PIN	-PS Serial		-BC CANopen		-BP PROFIBUS DP	
	SIGNAL	TECHNICAL SPECIFICATION	SIGNAL	TECHNICAL SPECIFICATION	SIGNAL	TECHNICAL SPECIFICATION
1	NC	do not connect	CAN_SHLD	Shield	+5V	for termination
2	NC	do not connect	NC	do not connect	LINE-A	Bus line (high)
3	RS_GND	Signal zero data line	CAN_GND	Signal zero data line	DGND	data line and termination Signal zero
4	RS_RX	Valves receiving data line	CAN_H	Bus line (high)	LINE-B	Bus line (low)
5	RS_TX	Valves transmitting data line	CAN_L	Bus line (low)	SHIELD	

7.3 ELECTRONIC CONNECTIONS - 4 PIN REMOTE PRESSURE TRANSDUCER M8 CONNECTOR (only for AERS)

PIN	standard version		/C option (Ri = 316 Ω)	
1	TR	remote trasducer pressure signal (0 \div +10 Vdc)	TR	remote trasducer pressure signal (4 \div 20 mA)
2	NC	reserved (do not connect)	NC	reserved (do not connect)
3	VT	remote transducer power supply +24 Vdc	VT	remote transducer power supply +24 Vdc
4	AGND	signal zero for power supply and signal	NC	reserved (do not connect)

See tab. G465 for the pressure transducer characteristics and connections.

8 SOFTWARE TOOLS

The driver configuration and parameters can be easily set with the Atos E-SW programming software, available in three different versions according to the driver's communication execution: E-SW-PS (Serial), E-SW-BC (CANopen) and E-SW-BP (PROFIBUS DP).

For a more detailed description of software interface, PC requirements, adapters, cables and terminators, please refer to technical table G500.

Programming software, must be ordered separately:

E-SW-* (mandatory - first supply) = Dvd including E-SW-***** software installer and operator manuals; it allows the registration to Atos digital service

E-SW-***-N** (optional - next supplies) = as above but not allowing the registration to Atos digital service

On first supply of the E-SW-***** software, it is required to apply for the registration in the Atos download area: www.download.atos.com.

Once the registration is completed, the password will be sent by email.

The software remains active for 10 days from the installation date and then it stops until the user inputs his password.

With the password you can also download, in your personal area, the latest releases of the Atos software, manuals, drivers and configuration files.

9 DIAGRAMS (based on mineral oil ISO VG 46 at 50 °C)

9.1 Regulation diagrams
with flow rate $Q = 50$ l/min

1 = AGMZO-TERS, AGMZO-AERS

Notes:

The presence of counter pressure at port T can affect the effective pressure regulation.

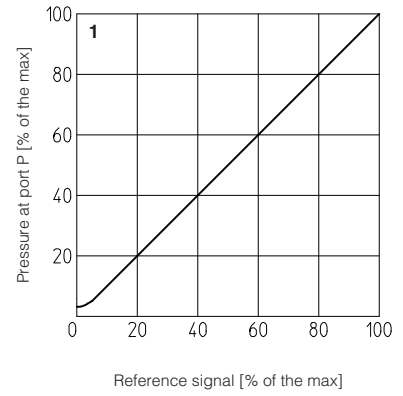

9.2 Pressure/flow diagrams
with reference pressure set at $Q = 50$ l/min

2 = AGMZO-TERS, AGMZO-AERS

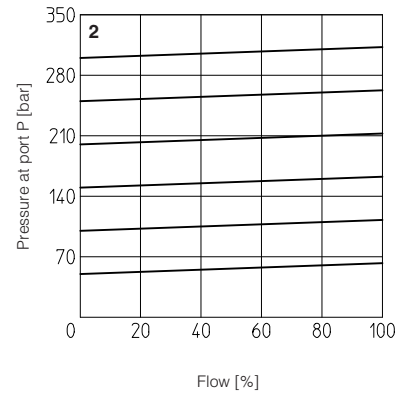

9.3 Min. pressure/flow diagrams
with zero reference signal

- 3 = AGMZO-* -10
- 4 = AGMZO-* -20
- 5 = AGMZO-* -32

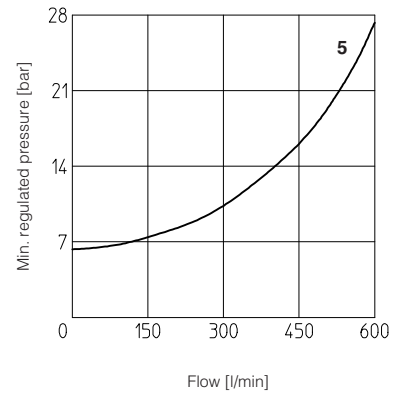
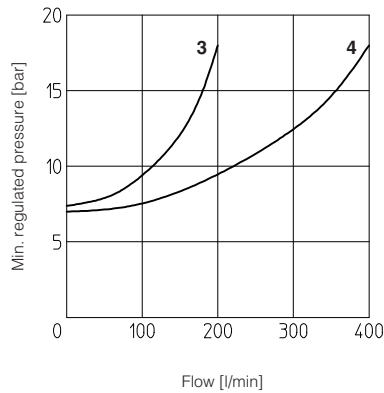

9.4 Dynamic response

The response times in section 3 have to be considered as average values.

The pressure variation in consequence of a modification of the reference input signal to the valve is affected by the stiffness of the hydraulic circuit: greater is the stiffness of the circuit, faster is the dynamic response. The valves dynamic performances can be optimized depending on the stiffness characteristics of the hydraulic circuit, by setting the internal software parameters. This regulation is particularly helpful in case of circuits with accumulators and/or with great fluid volumes and/or with long hoses.

10 INSTALLATION DIMENSIONS of AGMZO [mm]

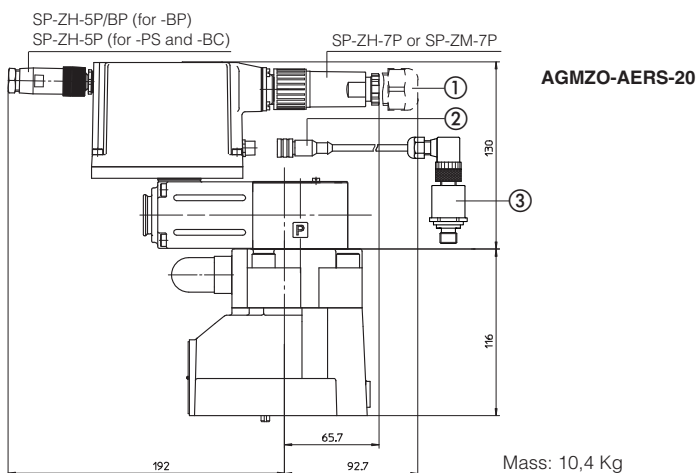
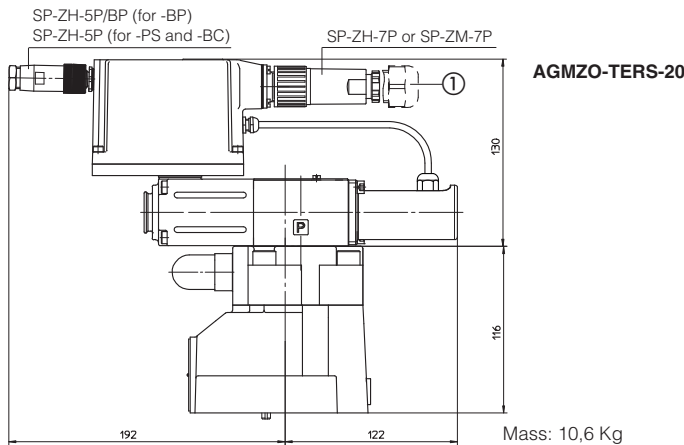
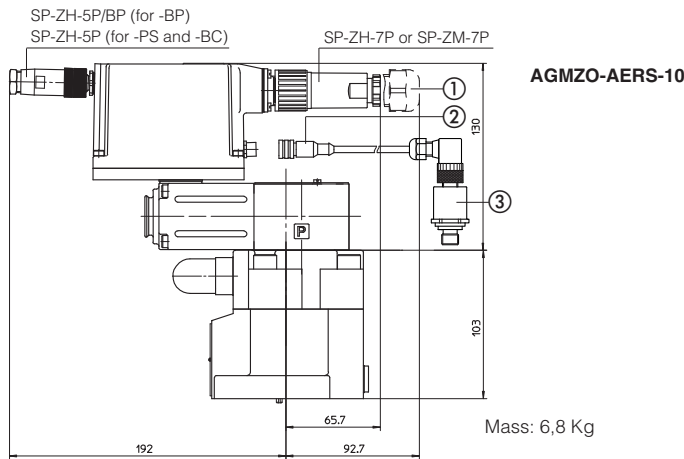
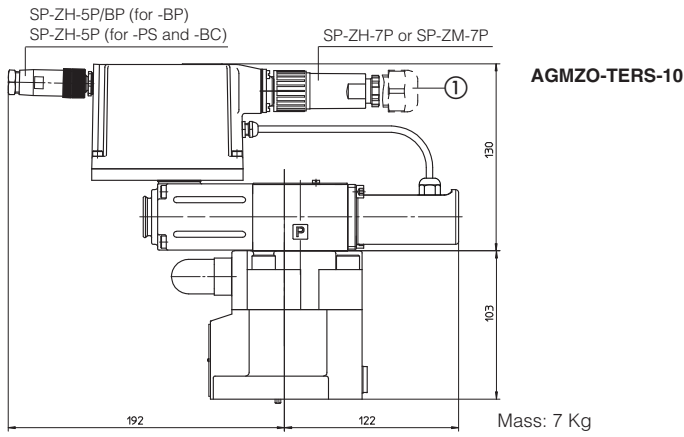

INSTALLATION DIMENSIONS of AGMZO-*10 [mm]

ISO 6264: 2007
Mounting surface: 6264-06-09-0-97 (see table P005)
 Fastening bolts: 4 socket head screws
 M12x35 class 12.9
 Tightening torque = 125 Nm
 Seals: 2 OR 123, 1 OR 109/70
 Ports P, T: $\varnothing = 14$ mm
 Port X: $\varnothing = 3,2$ mm

- ① = 12 pin connector SP-ZH-12P (option/Z)
- ② = 4 pin connector SP-ZH-4P-M8/5 (see tab. G205)
- ③ = remote pressure transducer, to be ordered separately (see tab. G465)

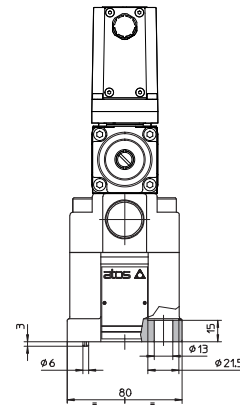

INSTALLATION DIMENSIONS of AGMZO-*20 [mm]

ISO 6264: 2007
Mounting surface: 6264-08-13-0-97 (see table P005)
 Fastening bolts: 4 socket head screws
 M16x50 class 12.9
 Tightening torque = 300 Nm
 Seals: 2 OR 4112, 1 OR 109/70
 Ports P, T: $\varnothing = 24$ mm
 Port X: $\varnothing = 3,2$ mm

- ① = 12 pin connector SP-ZH-12P (option/Z)
- ② = 4 pin connector SP-ZH-4P-M8/5 (see tab. G205)
- ③ = remote pressure transducer, to be ordered separately (see tab. G465)

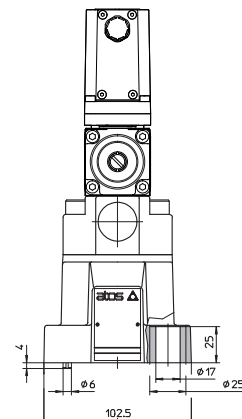

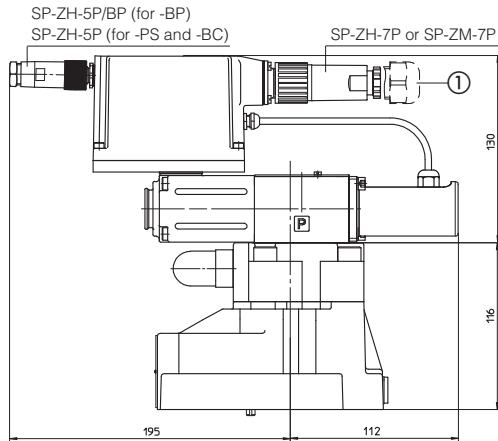

AGMZO-TERS-32

Mass: 13,3 Kg

INSTALLATION DIMENSIONS of AGMZO*-32 [mm]

ISO 6264: 2007

**Mounting surface: 6264-10-17-0-97 (see table P005)
(with M20 fixing holes instead of standard M18)**

Fastening bolts: 4 socket head screws

M20x60 class 12.9

Tightening torque = 600 Nm

Seals: 2 OR 4131, 1 OR 109/70

Ports P, T: $\varnothing = 28$ mm

Port X: $\varnothing = 3,2$ mm

① = 12 pin connector SP-ZH-12P (option/Z)

② = 4 pin connector SP-ZH-4P-M8/5 (see tab. G205)

③ = remote pressure transducer, to be ordered separately
(see tab. G465)

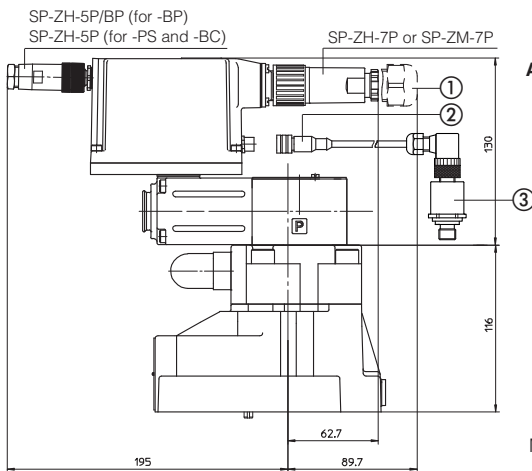

AGMZO-AERS-32

Mass: 13,1 Kg

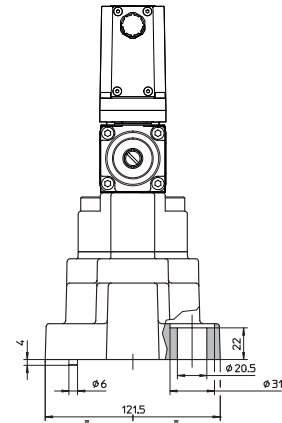

11 MODEL CODES OF POWER SUPPLY AND COMMUNICATION CONNECTORS (to be ordered separately)

VALVE VERSION	-AERS, -TERS		-AERS/ -TERS/Z	-Serial (-PS) or CANopen (-BC)	PROFIBUS DP (-BP)	Pressure transducer only for -AERS
CONNECTOR CODE	SP-ZH-7P	SP-ZM-7P	SP-ZH-12P	SP-ZH-5P	SP-ZH-5P/BP	SP-ZH-4P-M8/5 (1)
PROTECTION DEGREE	IP67	IP67	IP67	IP67	IP67	IP67
DATA SHEET	G205, K500					

(1) M8 connector SP-ZH-4P-M8/5 moulded on cable 5 mt lenght for pressure transducer